

~ Office Space In Downtown Winnipeg ~



**FOR LEASE**

# 254 Edmonton Street

**WINNIPEG, MB**

TREVOR CLAY, Broker, Principal  
(204) 985-1365

[trevor.clay@capitalgrp.ca](mailto:trevor.clay@capitalgrp.ca)

Services provided by Trevor Clay Personal Real Estate Corporation

**Capital**  
COMMERCIAL REAL ESTATE  
SERVICES INC.

[capitalgrp.ca](http://capitalgrp.ca)

# Property Overview

## PROPERTY DETAILS

AREA AVAILABLE (+/-)	Unit 204 Third Floor	900 sq. ft. 9,851 sq. ft.
NET RENTAL RATE	\$11.00 per sq. ft.	
ADDITIONAL RENT	\$10.78 per sq. ft. including mgmt fees	
AVAILABILITY	Immediately	

## PROPERTY HIGHLIGHTS

- Walking distance to Canada Life Centre, True North Square and Cityplace Winnipeg
- Adjacent to Graham Avenue Winnipeg Transit Hub serving 20 bus routes
- Upcoming building upgrades to include, exterior brick re-painting, new canopy, building entrance and elevator lobby renovation, and roof

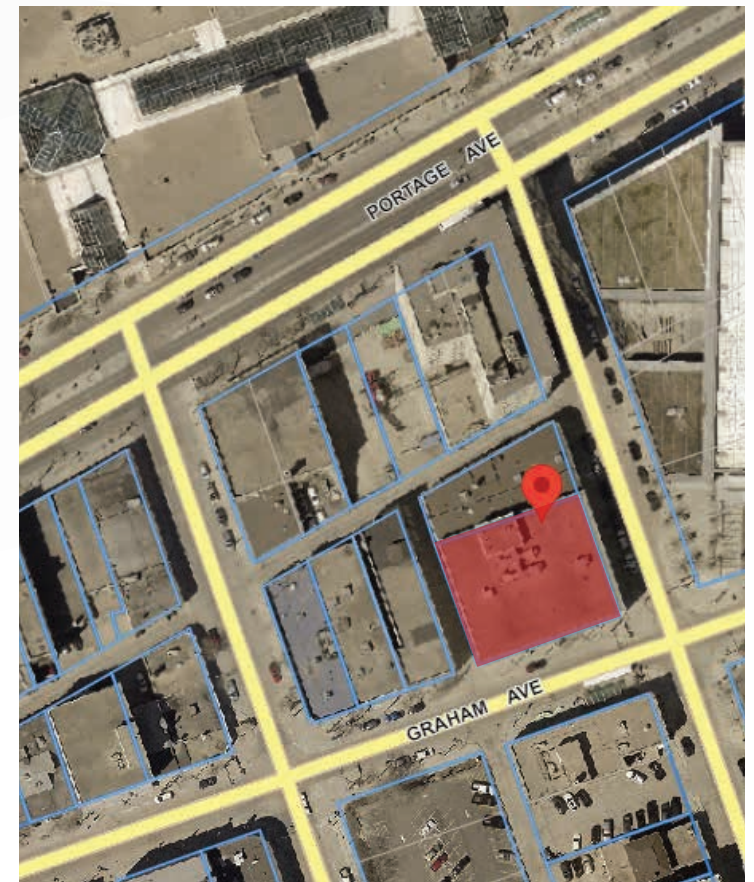

# Nearby Parking Opportunities

#	PARKADE	ADDRESS	TOTAL STALLS	RATES (\$ PER MONTH)
1	Portage Place Parkade	393 Portage Avenue	1,000 stalls*	\$225.00
2	Rice Centre Parkade - Lot #16	491 Portage Avenue	388 stalls*	\$155.00
3	Winnipeg Clinic - Lot #326	240 Kennedy Street	24 stalls*	\$190.00
4	Medical Arts - Lot #371	223 Kennedy Street	434 stalls*	\$175.00
5	Bay Parkade - Lot #204	450 Portage Avenue	750 stalls*	\$170.00
6	Winnipeg Clinic - Lot #325	425 St. Mary Avenue	58 stalls*	\$190.00
7	444 St. Mary Parkade - Lot #85	180 Kennedy Street	363 stalls*	\$215.00

\*Subject to availability



# The SHED District

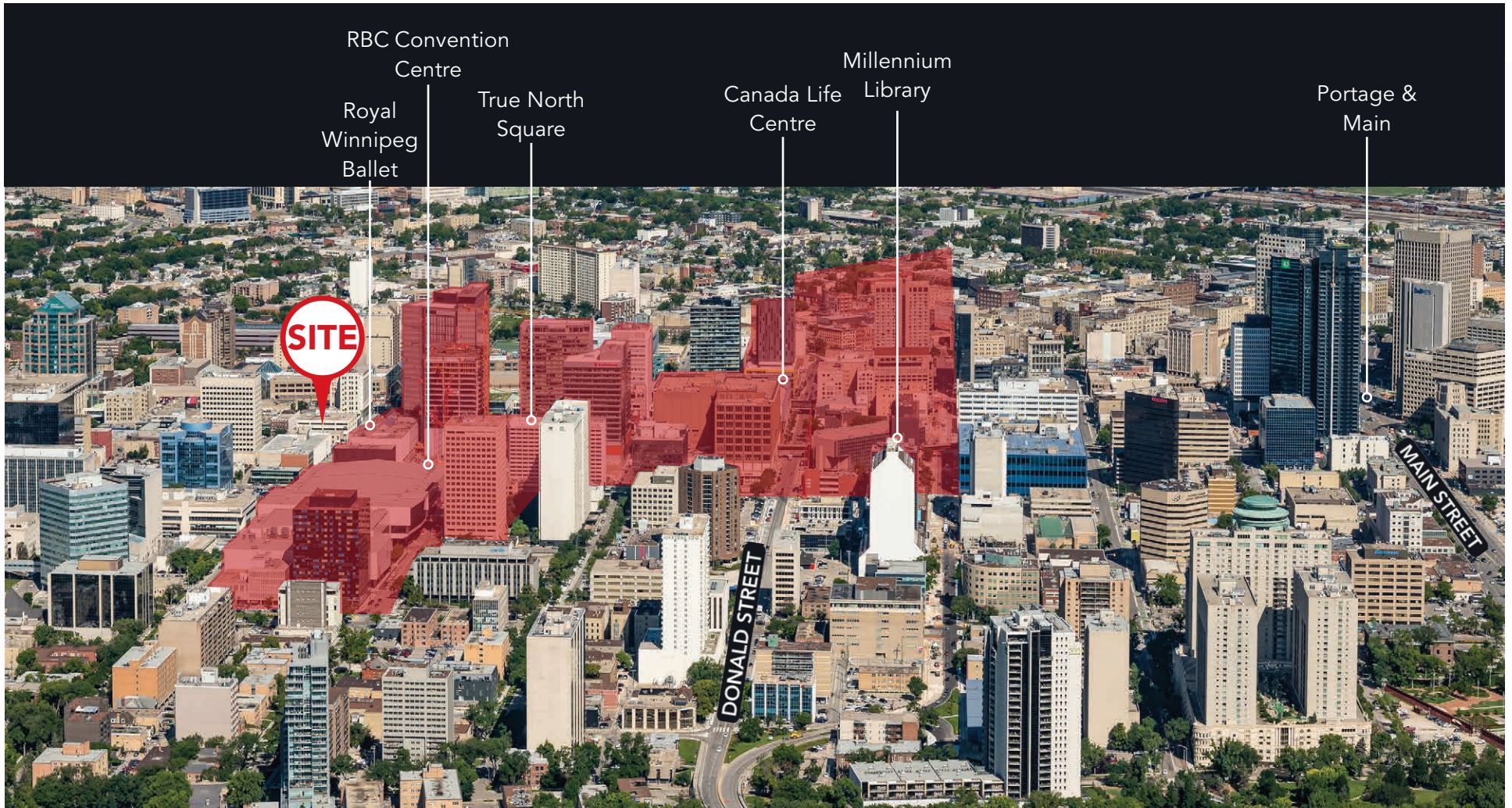

**11**

city blocks

**4**

hotels including the new Alt Hotel and the 288-room Sutton Place Hotel now under construction

**20+**

restaurants including Merchant Kitchen Gusto North and Rudy's

**6**

entertainment & sports venues including the Royal Winnipeg Ballet, Canada Life Centre, and the MET



MANITOBA HYDRO

TRUE NORTH SQUARE

ROYAL WINNIPEG BALLET

**SITE**

BOVD MEDICAL CENTRE

ROYAL WINNIPEG BALLET

PINNACLE  
WIND-PANNELS.COM

# Floor Plan

## UNIT 204

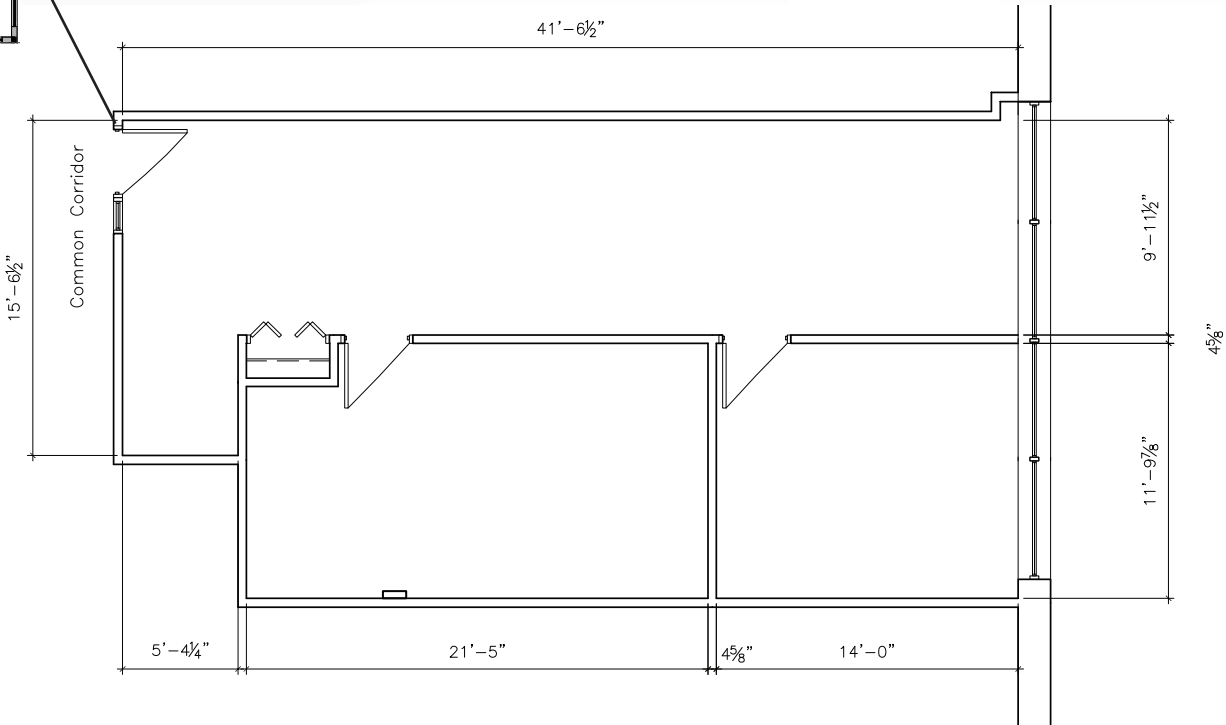
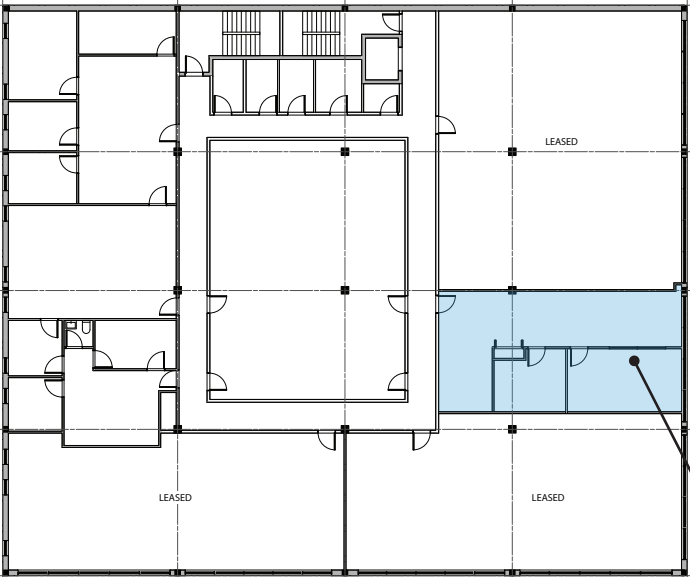



COMMERCIAL REAL ESTATE  
SERVICES INC.

## Contact

TREVOR CLAY, Broker, Principal

(204) 985-1365

[trevor.clay@capitalgrp.ca](mailto:trevor.clay@capitalgrp.ca)

Services provided by Trevor Clay Personal Real Estate Corporation

**CAPITAL COMMERCIAL REAL ESTATE SERVICES INC.**

300-570 Portage Avenue, Winnipeg, MB R3C 0G4 | T (204) 943-5700 | F (204) 956-2783 | [capitalgrp.ca](http://capitalgrp.ca)

Disclaimer: Capital Commercial Real Estate Services Inc. ("Capital") does not accept or assume any responsibility or liability, direct or consequential, for the information set out herein, including, without limitation, any projections, images, opinions, assumptions and estimates obtained from third parties. This information has not been verified by Capital, and Capital does not guarantee the accuracy, correctness and completeness of this information. The recipient of this information should take such steps as the recipient may deem necessary to verify the information in this document prior to placing any reliance upon it. The information may change and any property described in this document may be withdrawn from the market at any time without notice or obligation to the recipient from Capital.